

REVISION		
REV.	DESCRIPTION	DATE

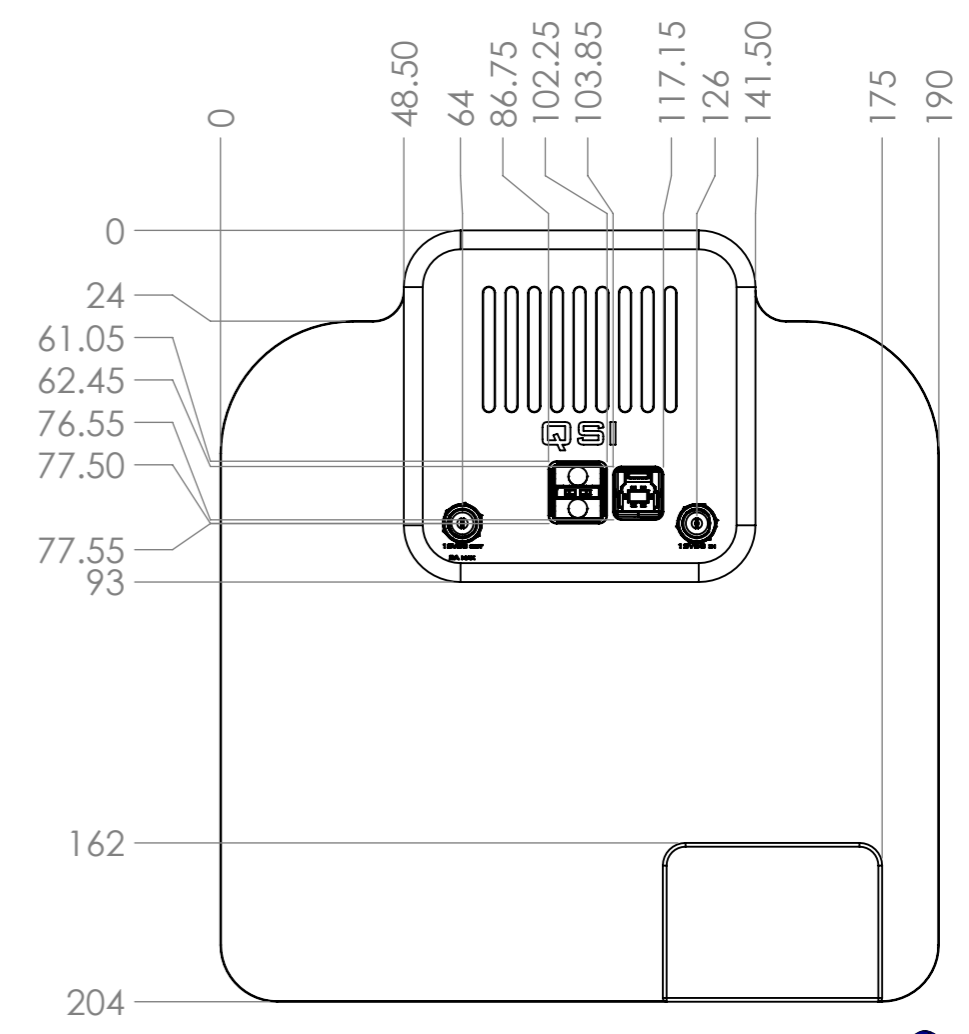

OBSERVATIONS:			
TOL. ISO-2768-fk ALL DIMENSIONS ARE IN mm		MATERIAL:	OVERALL DIMENSIONS:
OVERALL ROUGHNESS: 3.2/		SURFACE TREATMENT:	HEAT TREATMENT:
DEBURR AND BREAK SHARP EDGES: 0.2 x 45°		HARDNESS: Hrc	
3D	Marcelo Bernardes 24/06/2024	DESCRIPTION:	
2D	marcelobernades 04/11/2024	PART CODE:	QSI760W7
VERIF.		SYMMETRIC PART CODE:	QTY:
APROV.			SYMM QTY:

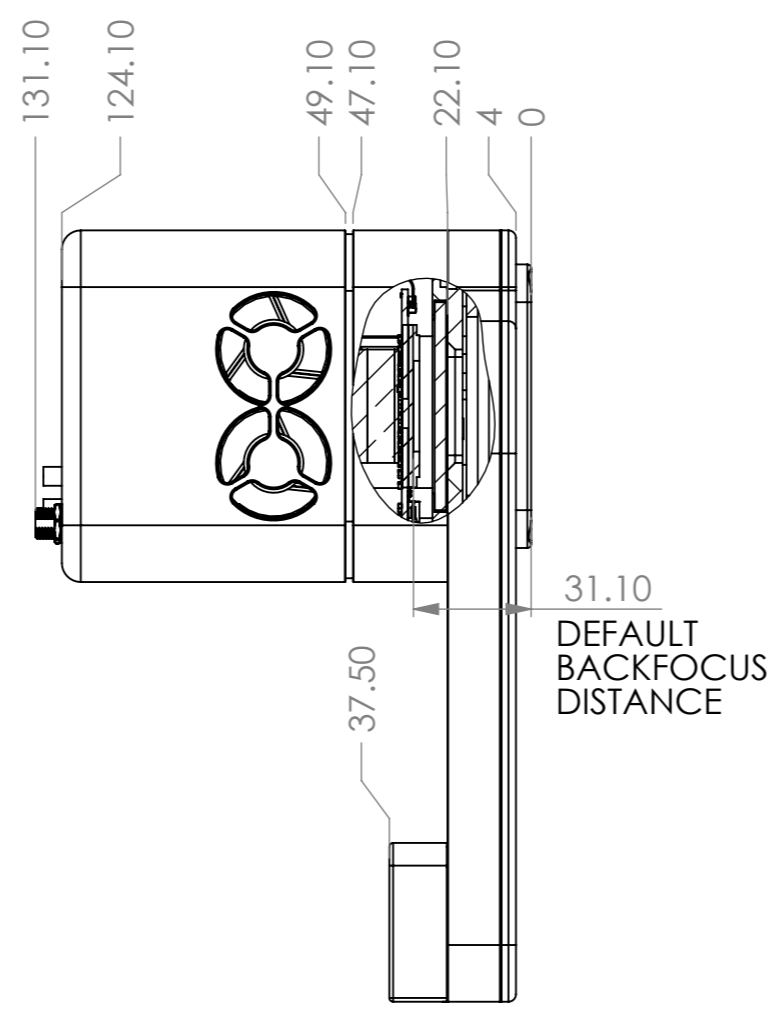
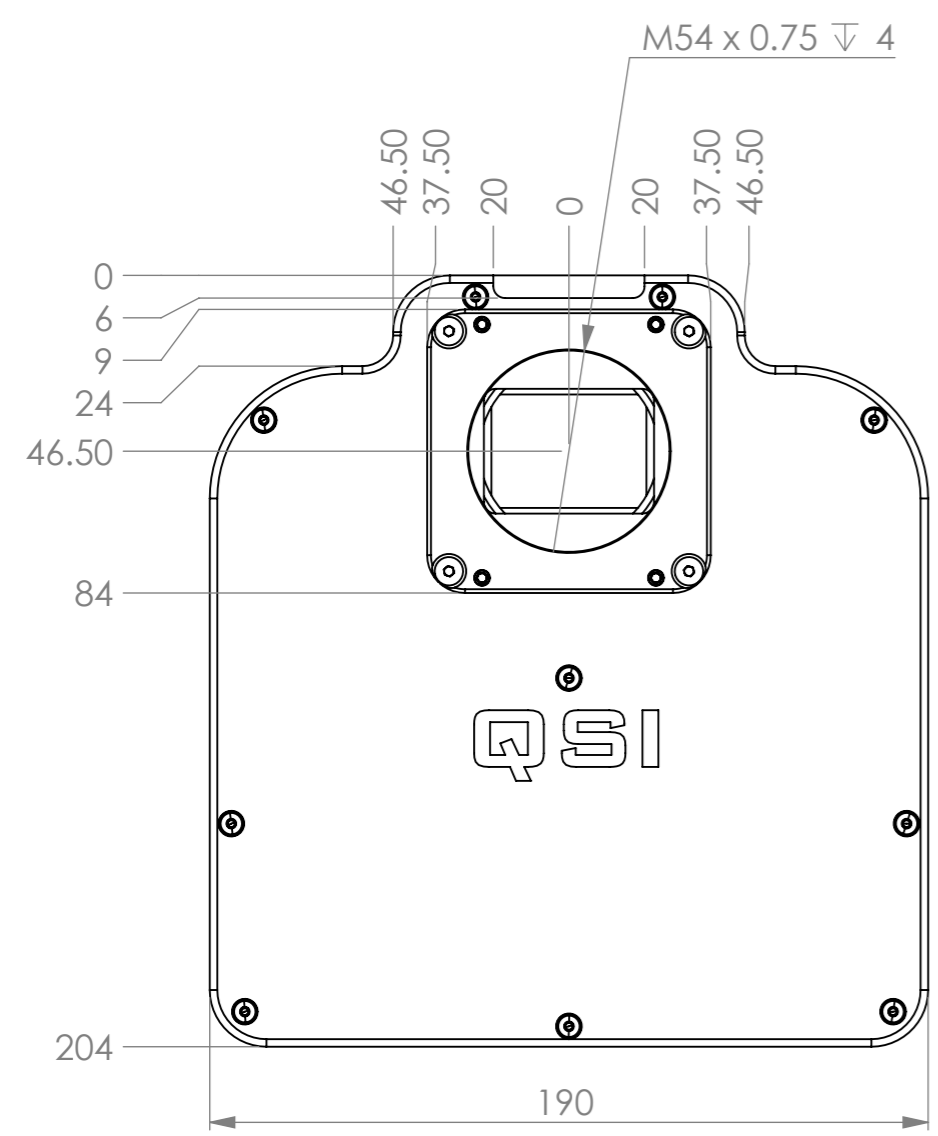

SCALE: 1:2

FILTER SIZE COMPATIBILITY:

- Ø 2" Mounted Filters;
- Ø 50.4 mm Unmounted Filters;

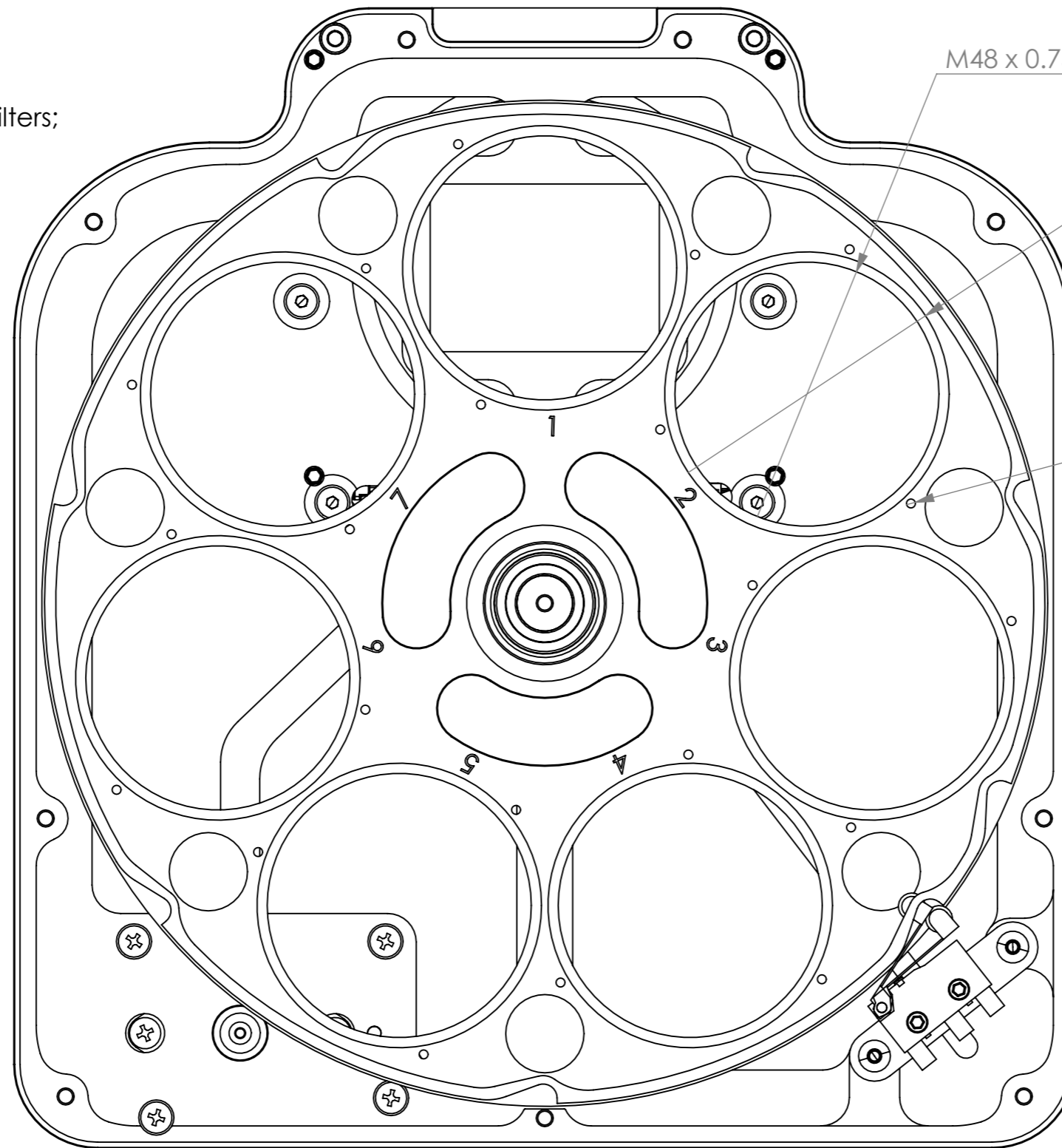

M48 x 0.75 THRU THREAD

Ø 50.90 x 2.95 DEPTH

3 x Ø 1.60 THRU
M2 - 6H THRU
(PER FILTER APERTURE)



OBSERVATIONS:				QSI	
TOL. ISO-2768-fk ALL DIMENSIONS ARE IN mm		MATERIAL:	OVERALL DIMENSIONS:	MASS (grams):	
OVERALL ROUGHNESS: DEBURR AND BREAK SHARP EDGES: 0.2 x 45°		SURFACE TREATMENT:	HEAT TREATMENT:	HARDNESS: Hrc	
3D	Marcelo Bernardes 24/06/2024	DESCRIPTION:			
2D	marcelobernades 04/11/2024	PART CODE:		QSI760W7	
VERIF.		SYMMETRIC PART CODE:		QTY:	
APROV.				SYMM QTY:	
		SCALE: 1:1			

CAMERA + OAG SETUP

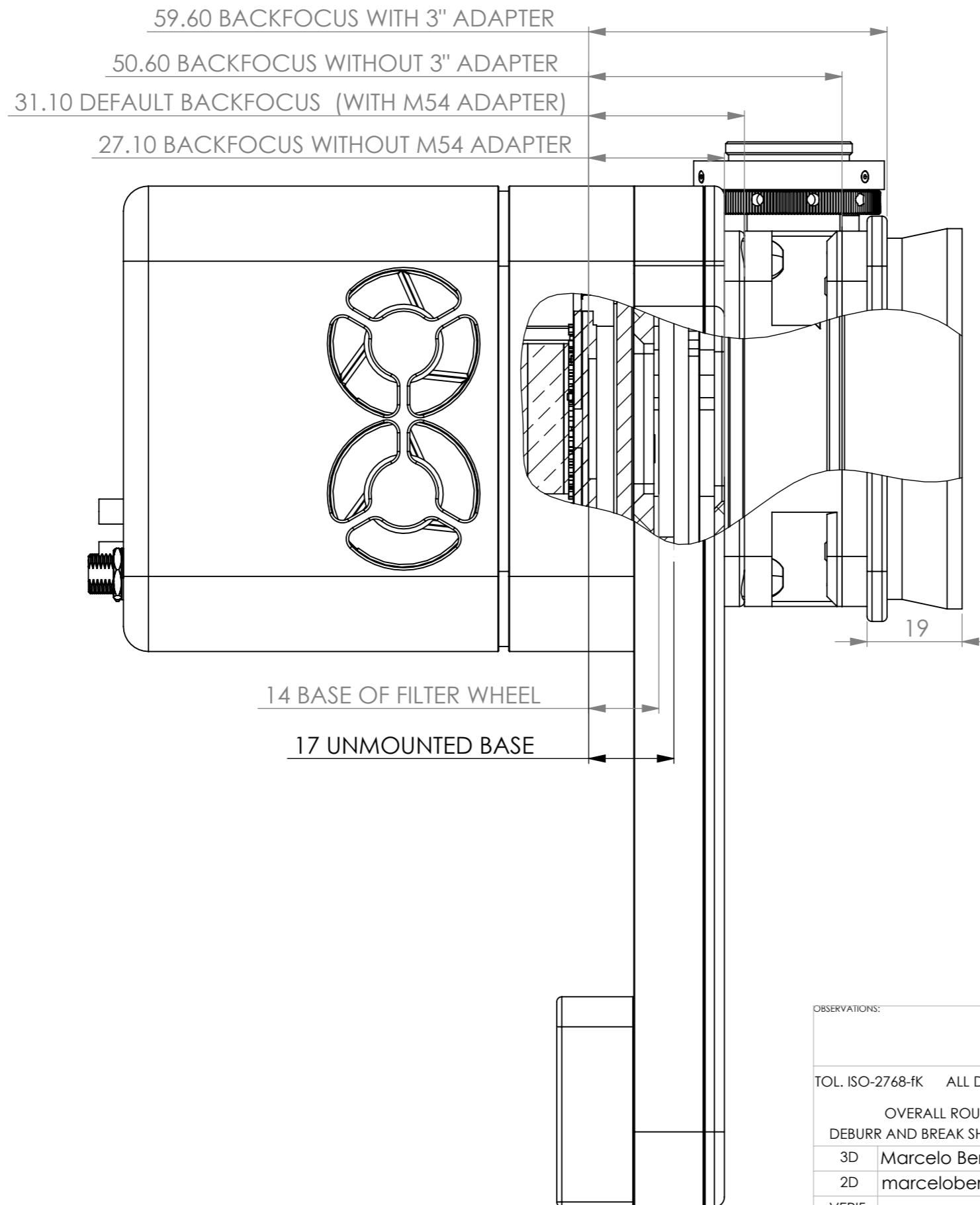

NOTES:

- DEFAULT GUIDE CAMERA ADAPTER IS CS-MOUNT;
- FOR 8.5MM BACKFOCUS GUIDER CAMERAS TO BE USED, THE M54 ADAPTER SHALL BE REMOVED;
- 3" DOVETAIL ADAPTER HAS AN INTERNAL THREAD OF M68 X 1.
- MAXIMUM FILTER CELL HEIGHT FOR MOUNTED FILTERS - 7.5MM

OBSERVATIONS:				QSI	
TOL. ISO-2768-fk ALL DIMENSIONS ARE IN mm		MATERIAL:	OVERALL DIMENSIONS:	MASS (grams):	
OVERALL ROUGHNESS: DEBURR AND BREAK SHARP EDGES: 0.2 x 45°		SURFACE TREATMENT:	HEAT TREATMENT:	HARDNESS: Hrc	
3D	Marcelo Bernardes 24/06/2024	DESCRIPTION:			
2D	marcelobernades 04/11/2024	PART CODE:		QSI760W7	
VERIF.		SYMMETRIC PART CODE:		QTY:	
APROV.				SYMM QTY:	
		SCALE: 1:1			